



3M | Glass Finishes

- 3M™ FASARA™ Glass Finishes
- 3M™ DI-NOC™ Glass Finishes
- 3M™ Dichroic Glass Finishes
- 3M™ Crystal Dusted and Frosted Glass Finishes



FOOTPRINT
CREATIVE

3M™ Glass Finishes

With over 100+ unique designs, patterns and textures, 3M™ Glass Finishes give you an easy way to add that extra element of design to your space.

At 3M we offer a variety of portfolios to choose from — each developed with a specific design need in mind, including: 3M FASARA™ Glass Finishes, 3M DI-NOC™ Glass Finishes, 3M Crystal Dusted and Frosted Glass Finishes, and 3M Dichroic Glass Finishes.

Our glass finish films are ideal for privacy and decorative applications in offices, hotels, retail stores, restaurants, healthcare environments, and designed for ease of application and cleaning.



Entrances



Glass Railings



Partitions



Staircases

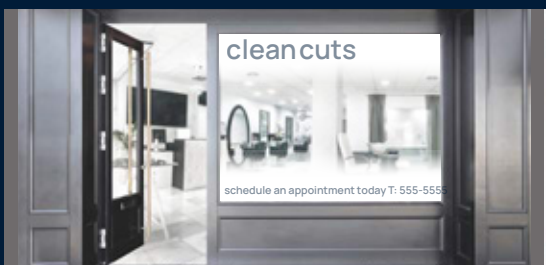

Windows



Conference Rooms



Doors



Corridors

3M™ FASARA™ Glass Finishes

- ▶ Made from a durable polyester film with a pressure-sensitive adhesive backing
- ▶ Capture the look of custom etched, cut or sandblasted glass
- ▶ Choose from a variety of patterns created in collaboration with leading designers from across the globe
- ▶ Tailor the light, privacy and style of your space
- ▶ Whiteboard WH-111G can turn any glass surface into a writable, erasable canvas



Print Direction

Print direction runs down the length of the roll for most designs that are not Gradation.

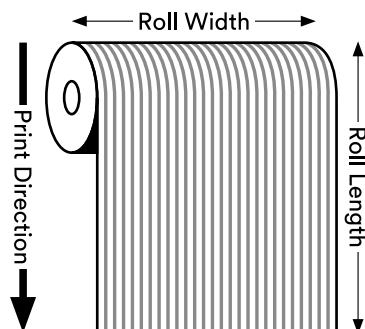

Print direction runs across the width of the roll for most Gradations.

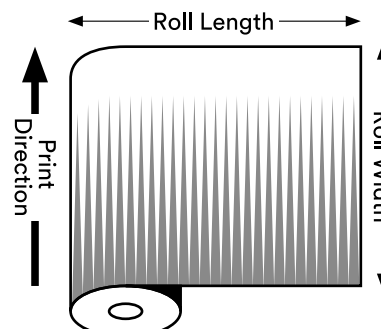

Gradation Transmission

No print
Clear Film
(Most Transparent)



For Gradations, percent is an estimate of Visible Light Transmission for the most transparent and least transparent sections of the pattern. These values are typical but not warranted.

Lower % Transmission
Pattern Area
(Least Transparent)

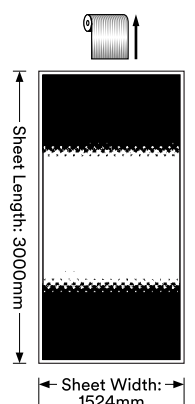

Illumina Seamless -W2

Rollup sheet products such as Illumina Seamless and Illumina Silky Gradations are provided in single sheets with the print direction down the sheet length, wound on a small roll.

3M™ DI-NOC™ Glass Finishes

- ▶ Provides durable glass surfaces with a dimensional appearance
- ▶ Apply under glass surfaces including walls, panels, table tops, shelves, fixtures and more
- ▶ Available in opaque designs such as abstract, stone, fabric, woodgrain and metallic



3M™ Crystal Dusted and Frosted Glass Finishes

- ▶ Achieve the look of sandblasted or etched glass
- ▶ Create custom cut shapes to promote your brand and design
- ▶ Provide privacy in interior or exterior spaces while keeping an open feel



3M™ Dichroic Glass Finishes

- ▶ Create dynamic, color-shifting appearance in cool or warm tones influenced by the environment
- ▶ Apply film on exterior or interior glass surfaces
- ▶ Transparent dichroic color effect changes color when viewed from different angles



Contents

3M™ FASARA™ Glass Finishes

	Pg.	Pattern Name	Product Code	width	length	same color
	Gradation					
NEW	7	Mist-W	SH2FGMI-W	60 in. (1524mm)	98.4 ft. (30m)	—
NEW	7	Mist-S	SH2FGMI-S	60 in. (1524mm)	98.4 ft. (30m)	—
NEW	7	Mist-PR	SH2FGMI-PR	60 in. (1524mm)	98.4 ft. (30m)	—
NEW	9	Pop-W	SH2FGPP-W	60 in. (1524mm)	98.4 ft. (30m)	—
NEW	9	Pop-S	SH2FGPP-S	50 in. (1270mm)	98.4 ft. (30m)	—
NEW	9	Oval	SH2FGOV	60 in. (1524mm)	98.4 ft. (30m)	—
NEW	9	Sand	SH2FGSD	60 in. (1524mm)	98.4 ft. (30m)	—
	9	Cloud	SH2FGCL	60 in. (1524mm)	98.4 ft. (30m)	—
	9	Cloud Narrow	SH2FGCN	50 in. (1270mm)	98.4 ft. (30m)	—
	9	Cloud Narrow Light Gray	SH2FGCNL	50 in. (1270mm)	98.4 ft. (30m)	—
	9	Cloud Narrow Blue Gray	SH2FGCNB	50 in. (1270mm)	98.4 ft. (30m)	—
	9	Cloud Narrow Dark Gray	SH2FGCND	50 in. (1270mm)	98.4 ft. (30m)	—
	11	Illumina Silky-W	SH2SSIM-W	50/60 in. (1270/1524mm)	9.6 ft. (2.95m)	—
	11	Illumina Silky-S	SH2SSIM-S	50/60 in. (1270/1524mm)	6.5 ft. (1.98m)	—
NEW	11	Illumina Seamless-W2	SH2SSIM-W2	60 in. (1524mm)	9.8 ft. (3m)	—
NEW	11	Illumina Seamless-S2	SH2SSIM-S2	60 in. (1524mm)	9.8 ft. (3m)	—
NEW	11	Illumina Seamless-PR	SH2SSIM-PR	60 in. (1524mm)	9.8 ft. (3m)	—
	13	Illumina	SH2FGIM	50 in. (1270mm)	98.4 ft. (30m)	Luce
	13	Illumina a	SH4FGIMX	50 in. (1270mm)	82 ft. (25m)	—
NEW	13	Illumina-PR	SH2FGIM-PR	60 in. (1524mm)	98.4 ft. (30m)	Luce
	13	Illumina-g	SH2FGIM-G	50 in. (1270mm)	98.4 ft. (30m)	Glace
	13	Illumina Reflect	SH2SIIM	50 in. (1270mm)	98.4 ft. (30m)	—
	13	Illumina Black	SH2BKIM	50 in. (1270mm)	98.4 ft. (30m)	Opaque Black
	15	Aerina	SH2FGAR	50 in. (1270mm)	98.4 ft. (30m)	Cielo
	15	Sabrina	SH2FGSB	50 in. (1270mm)	98.4 ft. (30m)	Mare
	15	Lontano	SH2FGLO	50 in. (1270mm)	98.4 ft. (30m)	—
	15	Venetian	SH2FGVN	50 in. (1270mm)	98.4 ft. (30m)	Luce
	15	Diamond	SH2FGDM	50 in. (1270mm)	98.4 ft. (30m)	Luce
	15	Tsurugi	SH2FGTG	50 in. (1270mm)	98.4 ft. (30m)	—
	Natural					
NEW	17	Shigure	SH2PTSG	50 in. (1270mm)	98.4 ft. (30m)	—
NEW	17	Shigure Gray	SH2GRSG	50 in. (1270mm)	98.4 ft. (30m)	—
NEW	17	Shigure Black	SH2BKSG	50 in. (1270mm)	98.4 ft. (30m)	—
NEW	17	Fibril	SH2PTFB	50 in. (1270mm)	98.4 ft. (30m)	—
NEW	17	Brushed	SH2FGBR	50 in. (1270mm)	98.4 ft. (30m)	—
NEW	17	Brushed Black	SH2BKBR	50 in. (1270mm)	98.4 ft. (30m)	—
NEW	19	Travertine	SH2FGTV	50 in. (1270mm)	98.4 ft. (30m)	—
NEW	19	Travertine Black	SH2BKTV	50 in. (1270mm)	98.4 ft. (30m)	—
NEW	19	Terrazzo	SH2FGTZ	50 in. (1270mm)	98.4 ft. (30m)	—

 For exterior applications

3M™ FASARA™ Glass Finishes

	Pg.	Pattern Name	Product Code	width	length	same color
NEW	19	Terrazzo Black	SH2BKTZ	50 in. (1270mm)	98.4 ft. (30m)	—
	Frost/Matte					
	21	Matte Crystal 2	SH2MACRX2	50 in. (1270mm)	98.4 ft. (30m)	—
	21	Matte Crystal-i	SH2MACR-I	50/60 in. (1270/1524mm)	98.4 ft. (30m)	—
	21	Fine Crystal	SH2FNCR	50/60 in. (1270/1524mm)	98.4 ft. (30m)	—
	21	Mare	SH2FGMR	50 in. (1270mm)	98.4 ft. (30m)	Sabrina
	21	Milky White	SH2MAML	40/50/60 in. (1016/1270/1524mm)	196.8 ft. (60m)	—
	21	Glace	SH2MAGL	50 in. (1270mm)	98.4 ft. (30m)	—
	21	Luce	SH2FGLU	50 in. (1270mm)	98.4 ft. (30m)	—
	21	Milky Crystal	SH2MLCRX	50 in. (1270mm)	98.4 ft. (30m)	—
	21	Milky Milky	SH2MAMM	50/60 in. (1270/1524mm)	98.4 ft. (30m)	—
	21	Lausanne	SH2EMLA	40/50 in. (1016/1270mm)	98.4 ft. (30m)	—
	21	Oslo	SH2EMOS	40/50/60 in. (1016/1270/1524mm)	98.4 ft. (30m)	—
	21	Essen	SH2EMES	50 in. (1270mm)	98.4 ft. (30m)	—
	21	Frost Matte	SH2FRMAX	50 in. (1270mm)	98.4 ft. (30m)	—
	21	Frost Sucre	SH2FRSCX	50 in. (1270mm)	98.4 ft. (30m)	—
	21	Chamonix	SH2EMCH	50 in. (1270mm)	98.4 ft. (30m)	—
	21	Cielo	SH2FGCE	50 in. (1270mm)	98.4 ft. (30m)	Aerina
	21	Opaque White	SH2MAOW	49.2 in. (1250mm)	98.4 ft. (30m)	—
	21	Whiteboard	WH-111-G	49.2 in. (1250mm)	98.4 ft. (30m)	—
	Reflect/Hairline					
	23	Milky Milky Light Gray	SH2MAMML	50 in. (1270mm)	98.4 ft. (30m)	—
	23	Milky Milky Dark Gray	SH2MAMMD	50 in. (1270mm)	98.4 ft. (30m)	—
	23	Milky Milky Blue Gray	SH2MAMMB	50 in. (1270mm)	98.4 ft. (30m)	—
	23	Opaque Black	SH2BKOP	50 in. (1270mm)	98.4 ft. (30m)	Illumina Black
	23	Hairline Matte	SH2HLMA	48 in. (1219mm)	98.4 ft. (30m)	—
	23	Reflect	RE1SIAR	50 in. (1270mm)	98.4 ft. (30m)	—
	23	Chain Mesh Reflect	SH2SICMR	50 in. (1270mm)	98.4 ft. (30m)	Reflect
	23	Cross Hairline Matte	SH2CHMA	48 in. (1219mm)	98.4 ft. (30m)	—
	23	Cross Hairline Sucre	SH2CHSC	48 in. (1219mm)	98.4 ft. (30m)	—
	23	Cross Hairline Milky	SH2CHML	48 in. (1219mm)	98.4 ft. (30m)	—
	23	Frost Walnut	SH2PTFW	60 in. (1524mm)	98.4 ft. (30m)	—
	23	Frost Walnut Smoke	SH2PTFWS	60 in. (1524mm)	98.4 ft. (30m)	—
	23	Cross Hairline Matte Light Gray	SH2CHMAL	48 in. (1219mm)	98.4 ft. (30m)	—
	Washi					
	25	Pyrgos	SH2PTPG	60 in. (1524mm)	98.4 ft. (30m)	—
	25	Straight Washi	SH2FGSW	50 in. (1270mm)	98.4 ft. (30m)	—
	25	Yamato	SH2PTYA	50 in. (1270mm)	98.4 ft. (30m)	—
	25	Altair	SH2FGAT	50 in. (1270mm)	98.4 ft. (30m)	—
	25	Vega	SH2FGVG	50 in. (1270mm)	98.4 ft. (30m)	—

Contents continued on next page >

3M™ FASARA™ Glass Finishes

Pg.	Pattern Name	Product Code	width	length	same color
25	Safu	SH2PTSF	50 in. (1270mm)	98.4 ft. (30m)	—
25	Sagano	SH2PTSA2	50 in. (1270mm)	98.4 ft. (30m)	—
25	Rikyu	SH2PTRK	50 in. (1270mm)	98.4 ft. (30m)	—
Fabric					
25	Sensai Linen	SH2FGSE	50 in. (1270mm)	98.4 ft. (30m)	—
25	Sensai Linen Champagne Gold	SH2CSSEC	50 in. (1270mm)	98.4 ft. (30m)	—
25	Grain Champagne Gold	SH2CSGC	50 in. (1270mm)	98.4 ft. (30m)	—
25	Linen	SH2FGLN	50 in. (1270mm)	98.4 ft. (30m)	—
25	Canvas	SH2FGCV	50 in. (1270mm)	98.4 ft. (30m)	—
25	Canvas Champagne Gold	SH2CSCVC	50 in. (1270mm)	98.4 ft. (30m)	—
25	Linen Crystal	SH2LNCR	50 in. (1270mm)	98.4 ft. (30m)	—
25	Buckram	SH2FGBU	50 in. (1270mm)	98.4 ft. (30m)	—
25	Weave Pearl	SH2EMWP	50 in. (1270mm)	98.4 ft. (30m)	—
25	Weave Pearl + Dark Gray	SH2EMWG	50 in. (1270mm)	98.4 ft. (30m)	—
25	Buckram Pearl + Gray	SH2FGBUG	50 in. (1270mm)	98.4 ft. (30m)	—
Border/Dot/Geometric					
27	Cut Glass	SH2CSC	50 in. (1270mm)	98.4 ft. (30m)	—
27	Cut Glass Pearl	SH2CSCP	50 in. (1270mm)	98.4 ft. (30m)	—
27	Astral Silver	SH2CSAS	50 in. (1270mm)	98.4 ft. (30m)	—
27	Vista	SH2FGVI	50 in. (1270mm)	98.4 ft. (30m)	Luce
27	Shizuku	SH2FGSK	50 in. (1270mm)	98.4 ft. (30m)	Luce
27	Kanon	SH2FGKN	50 in. (1270mm)	98.4 ft. (30m)	—
27	Aura 9	SH2PCA9	50 in. (1270mm)	98.4 ft. (30m)	Leise
27	Luna 6	SH2PCL6	50 in. (1270mm)	98.4 ft. (30m)	Luce
27	Luna 9	SH2PCL9	50 in. (1270mm)	98.4 ft. (30m)	Luce
27	Lattice	SH2FGLT	50 in. (1270mm)	98.4 ft. (30m)	—
27	Slat	SH2FGSL	50 in. (1270mm)	98.4 ft. (30m)	Luce
27	Slat-g	SH2FGSL-G	50 in. (1270mm)	98.4 ft. (30m)	Glaze
27	Paracell	SH2FGPR	50 in. (1270mm)	98.4 ft. (30m)	Luce
27	Pixela	SH2FGPX	50 in. (1270mm)	98.4 ft. (30m)	Luce
27	Leise	SH2FGLS	50 in. (1270mm)	98.4 ft. (30m)	Aura 9
Stripe					
29	Fusion Pearl	SH2CSFP	50 in. (1270mm)	98.4 ft. (30m)	—
29	Fine String	SH2PTFS	50 in. (1270mm)	98.4 ft. (30m)	—
29	String	SH2PTST	50 in. (1270mm)	98.4 ft. (30m)	—
29	Wind	SH2PTWD	50 in. (1270mm)	98.4 ft. (30m)	—
29	Safari	SH2PTSR	50 in. (1270mm)	98.4 ft. (30m)	—
29	String Reverse	SH2PTSTR	50 in. (1270mm)	98.4 ft. (30m)	—
29	Fine	SH2FGFN	50 in. (1270mm)	98.4 ft. (30m)	Luce
29	Seattle	SH2DGST	50 in. (1270mm)	98.4 ft. (30m)	—

 For exterior applications

3M™ FASARA™ Glass Finishes

Pg.	Pattern Name	Product Code	width	length	same color
29	Seattle Fine	SH2DGST-f	50 in. (1270mm)	98.4 ft. (30m)	—
29	Shutie	SH2FGST	50 in. (1270mm)	98.4 ft. (30m)	Luce
29	Shutie Black	SH2BKST	50 in. (1270mm)	98.4 ft. (30m)	—
29	Arpa	SH2FGAP	50 in. (1270mm)	98.4 ft. (30m)	Luce
29	Arpa Crystal	SH2APCR	50 in. (1270mm)	98.4 ft. (30m)	—
29	Arpa Black	SH2BKAP	50 in. (1270mm)	98.4 ft. (30m)	—

3M™ DI-NOC™ Glass Finishes

Pg.	Pattern Name	Product Code	width	length	same color
31	FW-1129DG Wood	—	48 in. (1220mm)	82.0 ft. (25m)	—
31	FW-1022DG Wood	—	48 in. (1220mm)	82.0 ft. (25m)	—
31	FW-1751DG Wood	—	48 in. (1220mm)	82.0 ft. (25m)	—
31	FA-1156DG Textile Silk	—	48 in. (1220mm)	82.0 ft. (25m)	—
31	MW-1419DG Metallic Wood	—	48 in. (1220mm)	82.0 ft. (25m)	—
31	FA-1161DG Abstract	—	48 in. (1220mm)	82.0 ft. (25m)	—
31	SI-1689DG Textile Silk	—	48 in. (1220mm)	82.0 ft. (25m)	—
31	NU-1786DG Textile	—	48 in. (1220mm)	82.0 ft. (25m)	—
31	SI-1613DG Textile Silk	—	48 in. (1220mm)	82.0 ft. (25m)	—
31	ME-1716DG Metallic Hairline	—	48 in. (1220mm)	82.0 ft. (25m)	—
31	ME-1434DG Metallic Hairline	—	48 in. (1220mm)	82.0 ft. (25m)	—
31	ME-379DG Metallic Hairline	—	48 in. (1220mm)	82.0 ft. (25m)	—
31	ME-432DG Metallic	—	48 in. (1220mm)	82.0 ft. (25m)	—
31	PA-180DG Metallic	—	48 in. (1220mm)	82.0 ft. (25m)	—
31	RT-1827DG Metallic Rust	—	48 in. (1220mm)	82.0 ft. (25m)	—
31	ST-1831DG Stone	—	48 in. (1220mm)	82.0 ft. (25m)	—
31	ST-1587DG Stone	—	48 in. (1220mm)	82.0 ft. (25m)	—
31	AE-1719DG Mortar	—	48 in. (1220mm)	82.0 ft. (25m)	—
31	FA-1678DG Abstract	—	48 in. (1220mm)	82.0 ft. (25m)	—
31	FA-1528DG Abstract	—	48 in. (1220mm)	82.0 ft. (25m)	—
31	PS-503DG Solid Color	—	48 in. (1220mm)	82.0 ft. (25m)	—
31	PS-504DG Solid Color	—	48 in. (1220mm)	82.0 ft. (25m)	—

3M™ Dichroic Glass Finishes

Pg.	Pattern Name	Product Code	width	length
33	Blaze	DF-PA Blaze	48 in. (1220mm)	98.4 ft. (30m)
33	Chill	DF-PA Chill	48 in. (1220mm)	98.4 ft. (30m)

3M™ Crystal Dusted and Frosted Glass Finishes

Pg.	Pattern Name	Product Code	width	length
35	Dusted White	7725SE-314	48/60 in. (1220/1524mm)	150 ft. (46m)
35	Frosted White	7725SE-324	48/60 in. (1220/1524mm)	150 ft. (46m)
35	Frosted Gold	7725SE-331	48 in. (1220mm)	150 ft. (46m)

Gradation



Mist-W SH2FGMI-W

Center Gradation



Example of Mist-W installation position

The same installation position is recommended for Pop-W, Oval, Sand and Cloud.

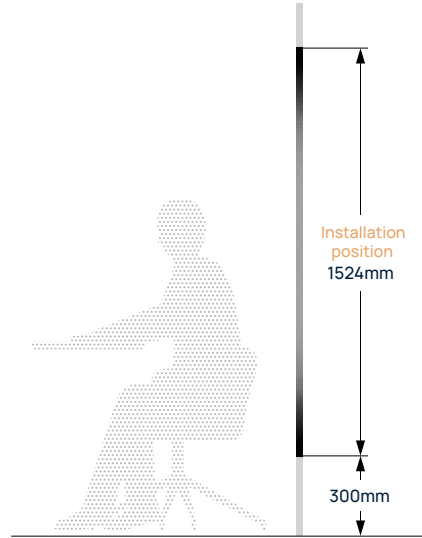

Mist-W

SH2FGMI-W NEW

Single Gradation

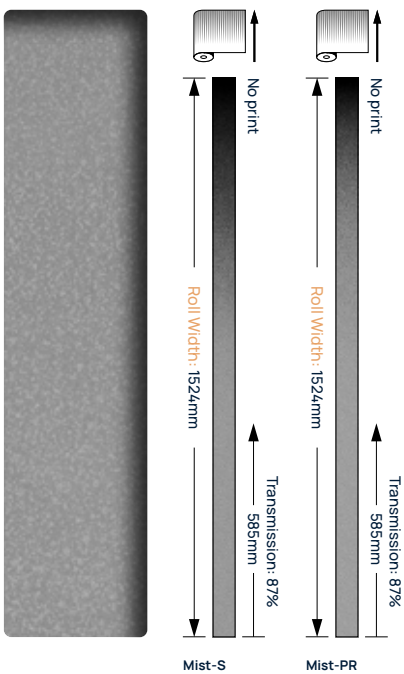

Mist-S



Mist-PR

SH2FGMI-S NEW

SH2FGMI-PR NEW

Mist-S and Mist-PR have different length of gradation.
Mist-PR design has a larger privacy gradation area than Mist-S.

Gradation



1 Pop-W SH2FGPP-W 2 Pop-S SH2FGPP-S

Center and Single Gradation

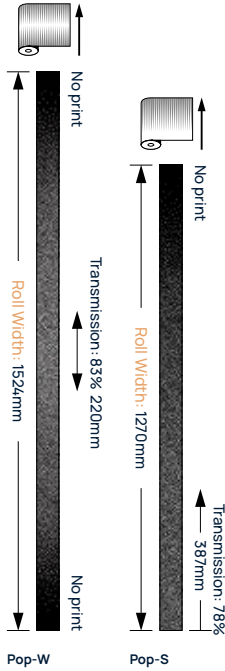
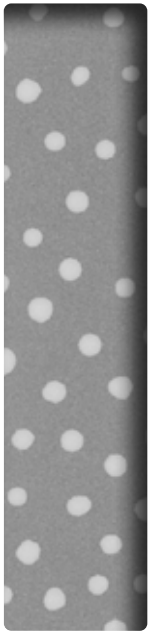

Pop-W

Pop-S

SH2FGPP-W NEW
(Center gradation type)

SH2FGPP-S NEW
(Single gradation type)

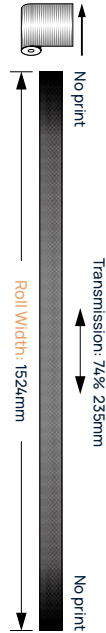

SH2FGOV NEW



Oval

Center Gradation

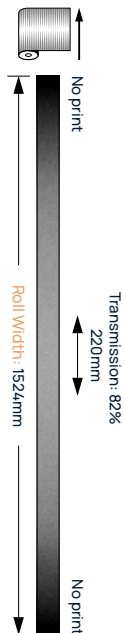
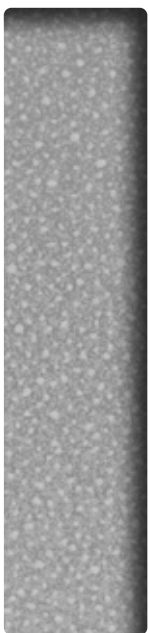

SH2FGSD NEW

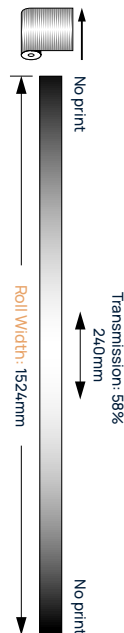
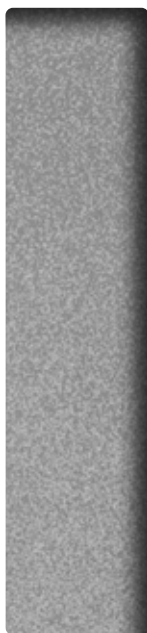

Cloud

SH2FGCL

SH2FGCN

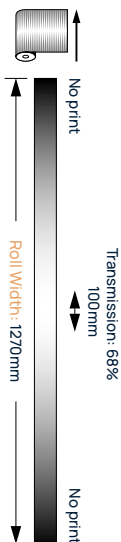

Cloud Narrow



Light Gray
SH2FGCNL



Blue Gray
SH2FGCNB



Dark Gray
SH2FGCND

Gradation



Illumina Seamless-W2SH2SSIM-W2

Gradation Sheets

Seamless series

A new gradation series that can cover a large area of glass with a single sheet without seams. Based on the popular Illumina Dot Gradation, the product is designed to ensure privacy without creating a sense of closure. A total of three variations are available, including center gradation, which becomes transparent at both ends of the sheet, single gradation, which becomes transparent at one end of the sheet and privacy single gradation which has a larger gradation area for more privacy coverage. Provided in single panel sheets with the print direction down the sheet length, wound on a small roll.

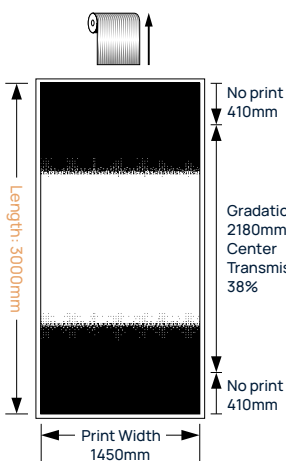

SH2SSIM-W2 NEW
(Center gradation type)

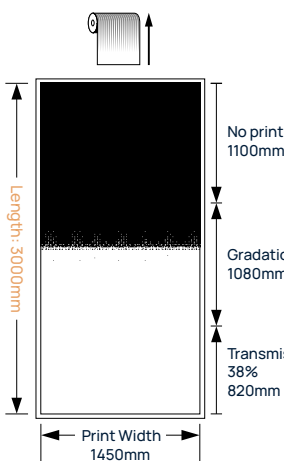

SH2SSIM-S2 NEW
(Single gradation type)

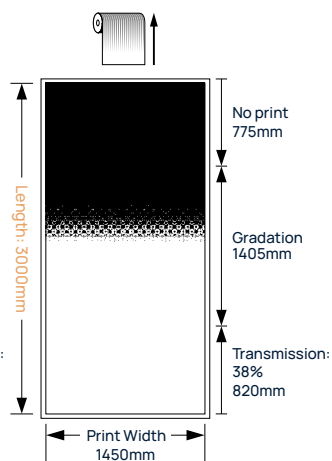

SH2SSIM-PR NEW
(Single gradation type)

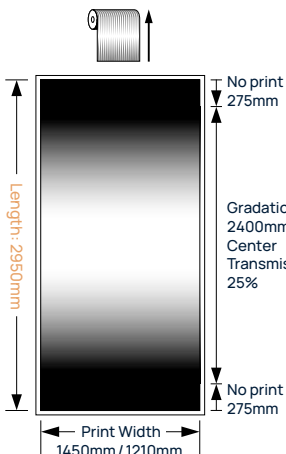

SH2SSIM-W
(Center gradation type)

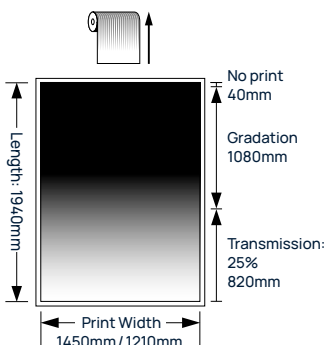

SH2SSIM-S
(Single gradation type)



Illumina Seamless-PR

Gradation



Reflect



Illumina Silky-W SH2SSIM-W

Single Gradation

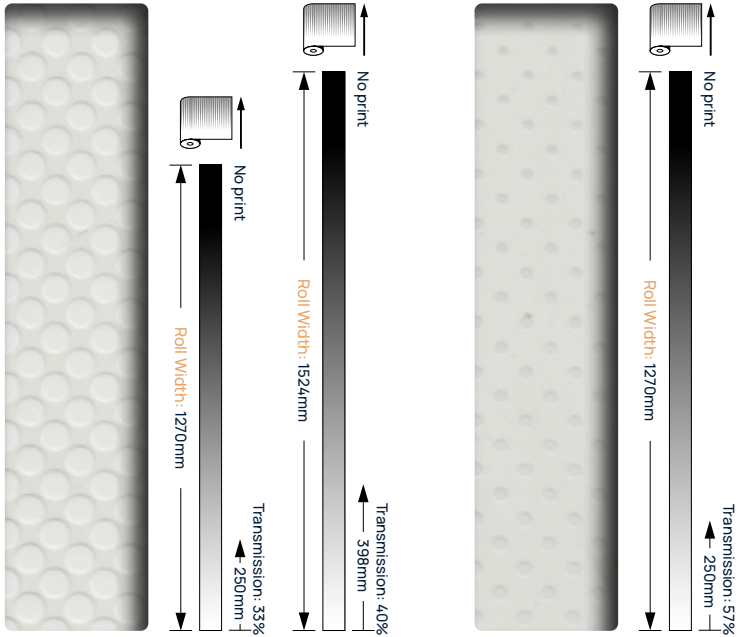

Illumina-PR

SH2FGIM + SH4FGIMX Exterior + SH2MAGL

Frost/Matte pattern with transmission and color that compliments Gradation pattern

SH2FGLU

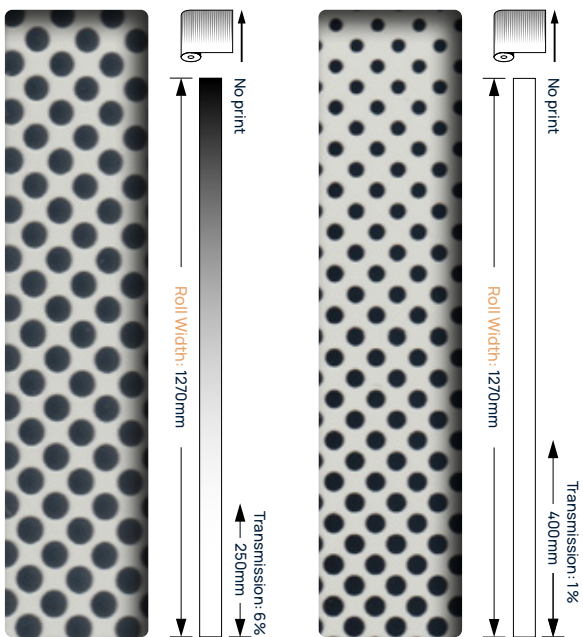

Illumina Reflect

SH2SIIM + RE1SIAR

SH2BKIM + SH2BKOP

Black

Gradation



Aerina SH2FGAR / Sabrina SH2FGSB / Lontano SH2FGLO / Tsurugi SH2FGTG / Venetian SH2FGVN

Single Gradation

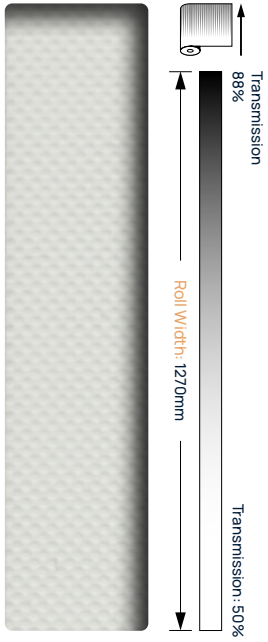

SH2FGAR

+

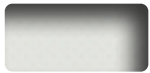

Frost/Matte pattern with transmission and color that compliments Gradation pattern

SH2FGCE



SH2FGSB

+



SH2FGMR



SH2FGLO



SH2FGVN

+



SH2FGLU

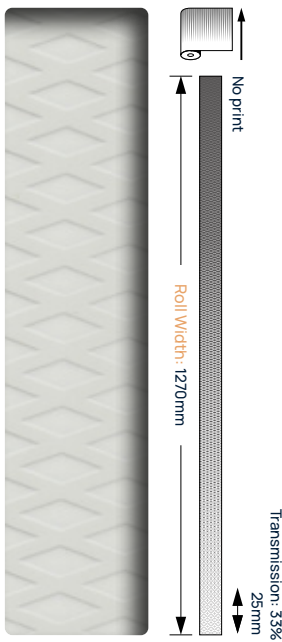

SH2FGDM

+



SH2FGLU



SH2FGTG



Tsurugi

Natural



1 Shigure SH2BKSG 2 Fibril SH2PTFB 3 BrushedBlack SH2BKBR

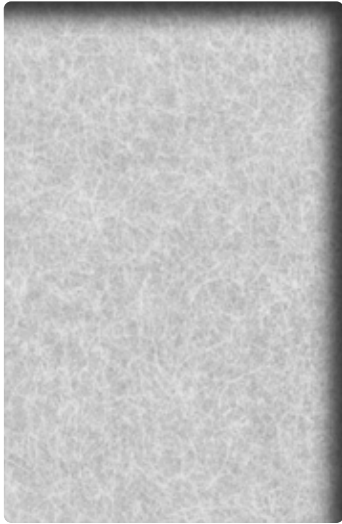

SH2PTSG NEW

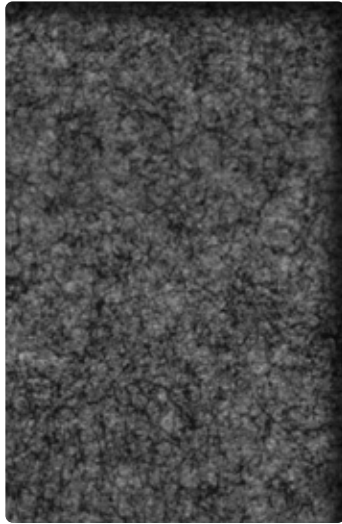

Gray
SH2GRSG NEW



Black
SH2BKSG NEW

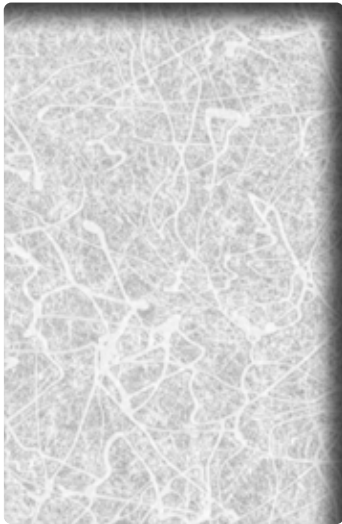

SH2PTFB NEW



SH2FGBR NEW



Black
SH2BKBR NEW

← Roll Width: 1270mm →

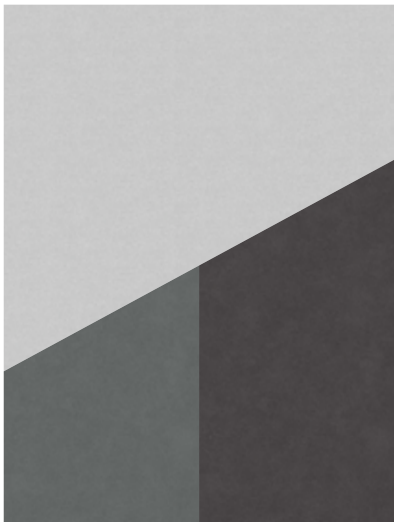

Shigure/ ShigureGray/ ShigureBlack

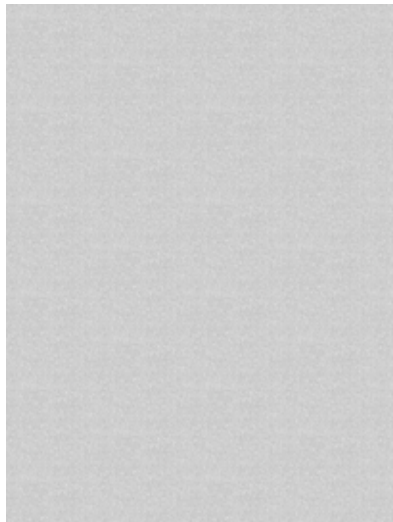

Fibril

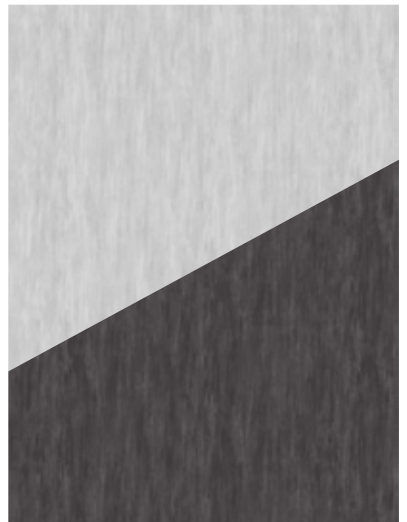

Brushed/ BrushedBlack

Natural

Natural



1 TerrazzoBlack SH2BKTZ 2 Travertine SH2FGTV 3 Terrazzo SH2FGTZ

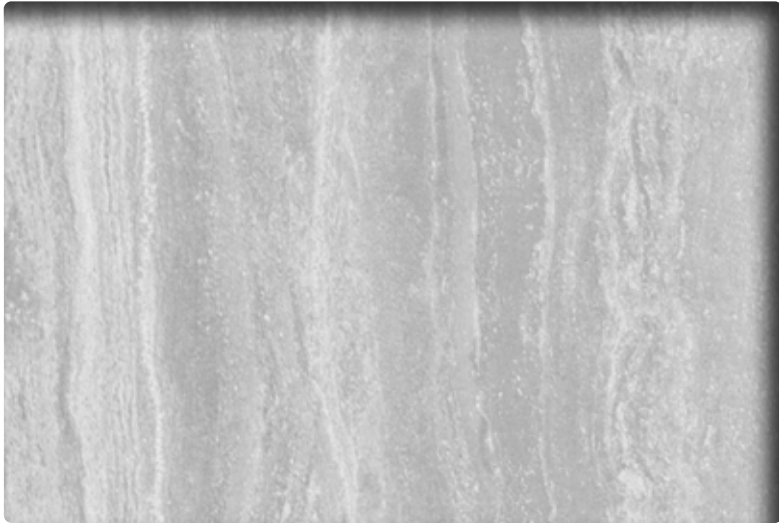

SH2FGTV **NEW**



Black
SH2BKTV **NEW**



SH2FGTZ **NEW**

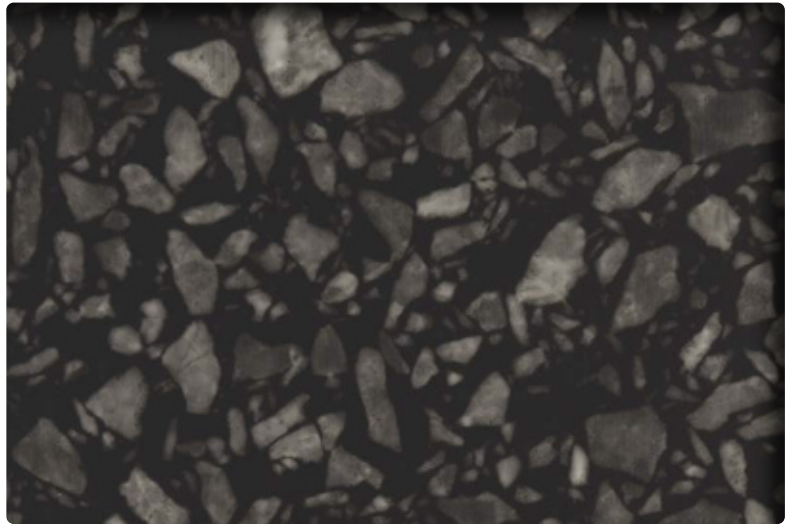

Black
SH2BKTZ **NEW**

← Roll Width: 1270mm →



Travertine / TravertineBlack

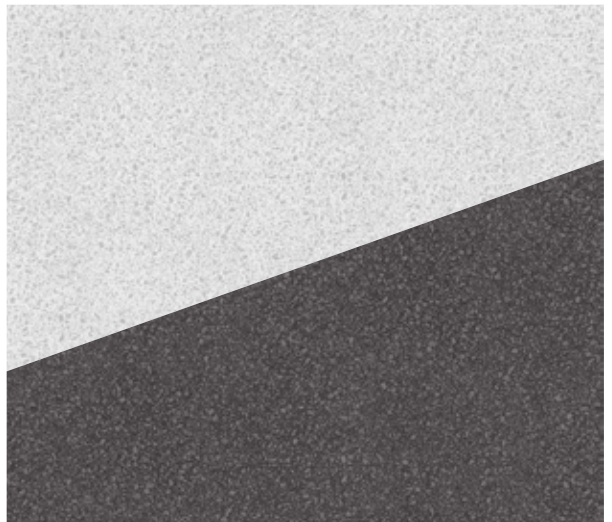

Terrazzo / TerrazzoBlack

*Image is scaled to show visual details

Frost/ Matte

Natural



SH2MACRX2  Exterior



SH2MACR-I



SH2FNCR



SH2FGMR



SH2MAML

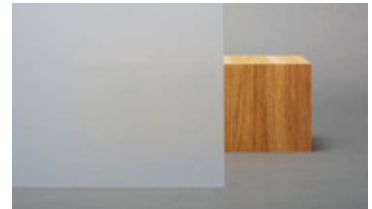

SH2MAGL

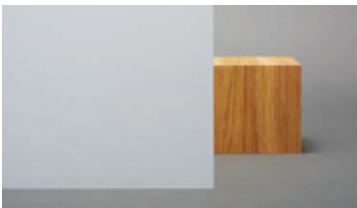

SH2FGLU

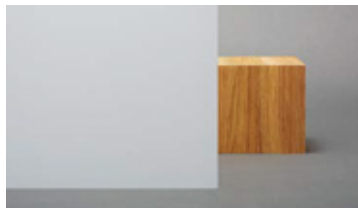

SH2MLCRX  Exterior

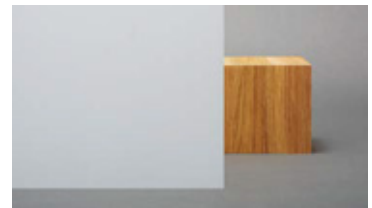

SH2MAMM



SH2EMLA



SH2EMOS



SH2EMES



SH2FRMAX  Exterior



SH2FRSCX  Exterior



SH2EMCH



SH2FGCE

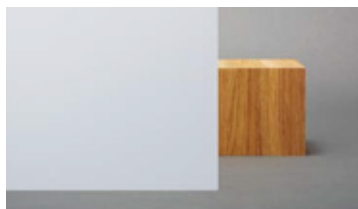

White
SH2MAOW

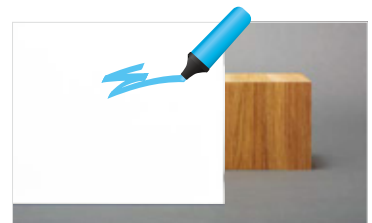

WH-111-G
(dry erase)

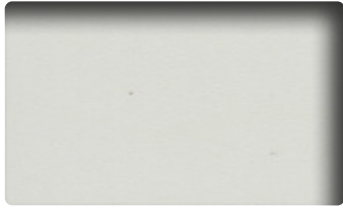

SH2MACRX2 Exterior (Transmission:87%)

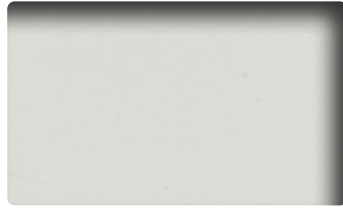

SH2MACR-I (85%)

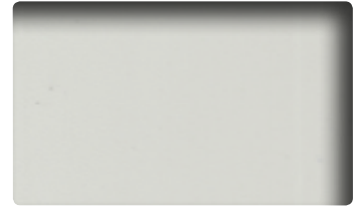

SH2FNCR (83%)

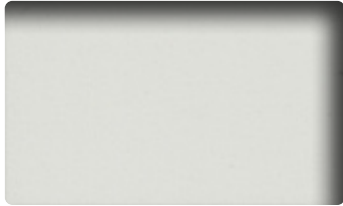

SH2FGMR (78%)

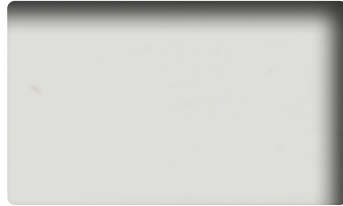

SH2MAML (60%)

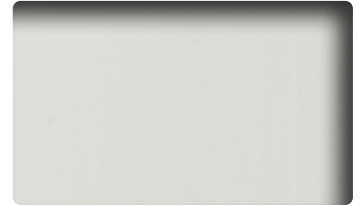

SH2MAGL (57%)



SH2FGLU (33%)

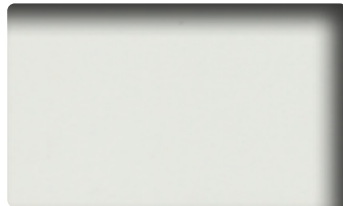

SH2MLCRX Exterior (26%)



SH2MAMM (28%)

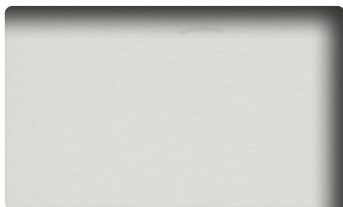

SH2EMLA (85%)

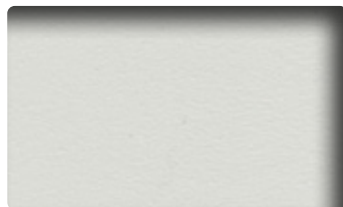

SH2EMOS (82%)

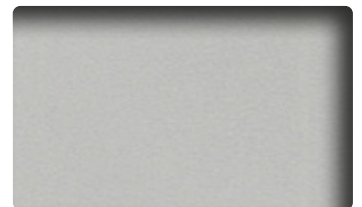

SH2EMES (49%)



SH2FRMAX Exterior (89%)

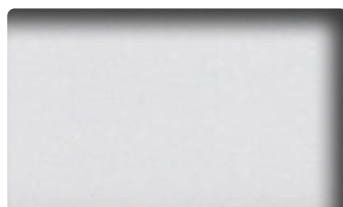

SH2FRSCX Exterior (57%)

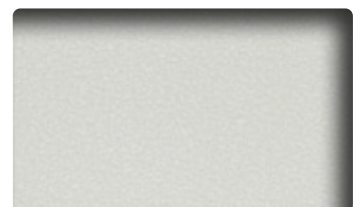

SH2EMCH (48%)

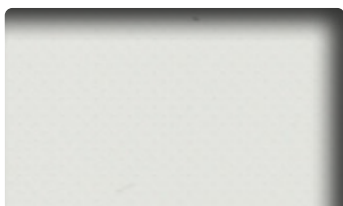

SH2FGCE (50%)



White
SH2MAOW (6%)



(dry erase)
WH-111-G

Reflect / Hairline

Frost / Matte



Cross HairlineMatte SH2CHMA



Light Gray

SH2MAMML <Transmission:61%



Dark Gray

SH2MAMMD <51%



Blue Gray

SH2MAMMB <55%



Black

SH2BKOP <1%

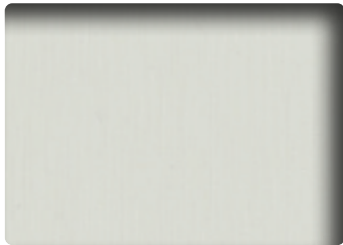

Matte

SH2HLMA <90%

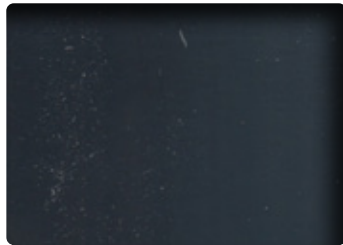

Reflect

RE1SIAR

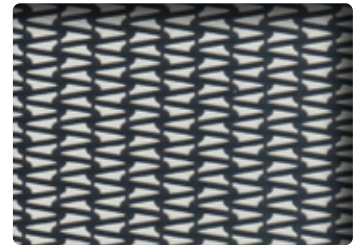

Reflect

SH2SICMR

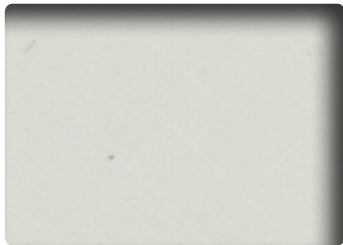

Matte

SH2CHMA <90%

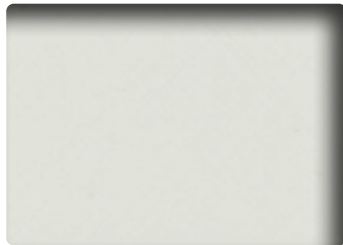

Sucre

SH2CHSC <57%

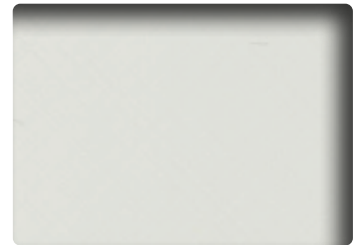

Milky

SH2CHML <26%

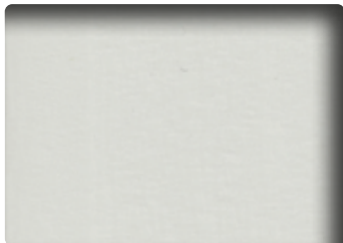

SH2PTFW <87%

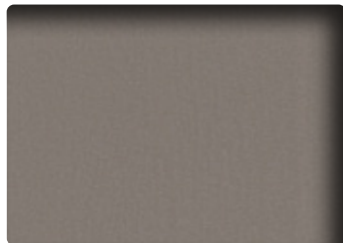

Smoke

SH2PTFWS <49%

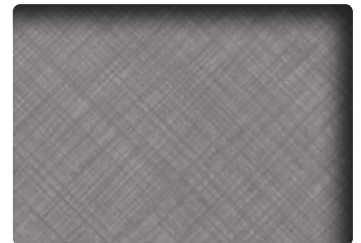

Matte Light Gray

SH2CHMAL <51%

Washi/ Fabric

Reflect / Hairline



Pyrgos SH2PTPG



Buckram Pearl + Gray SH2FGBUG

← Roll Width →

↑ Roll Length ↓

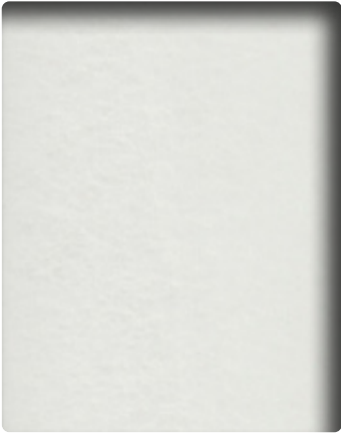

SH2PTPG



SH2FGSW

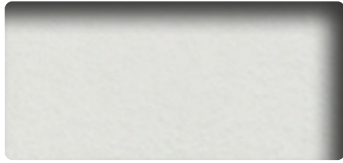

SH2PTYA



SH2FGAT



SH2FGVG

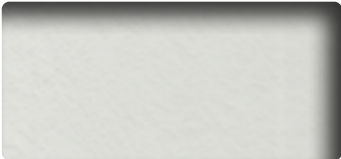

SH2PTSF

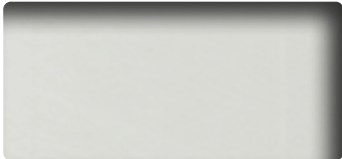

SH2PTSA2

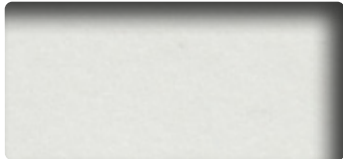

SH2PTRK

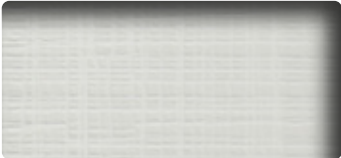

SH2FGSE

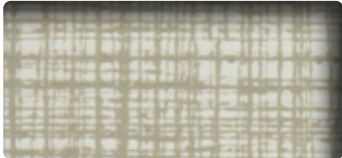

Champagne Gold

SH2CSSEC



Champagne Gold

SH2CSGC



SH2FGLN



SH2FGCV



Champagne Gold

SH2CSCVC



SH2LNCR



SH2FGBU



Pearl + Gray

SH2FGBUG

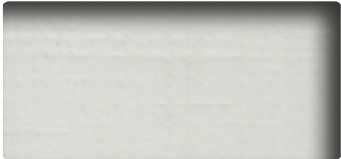

Pearl

SH2EMWP

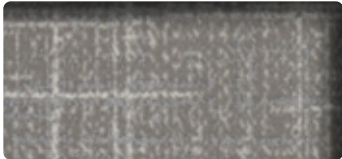

Pearl + Dark Gray

SH2EMWG

Geometric

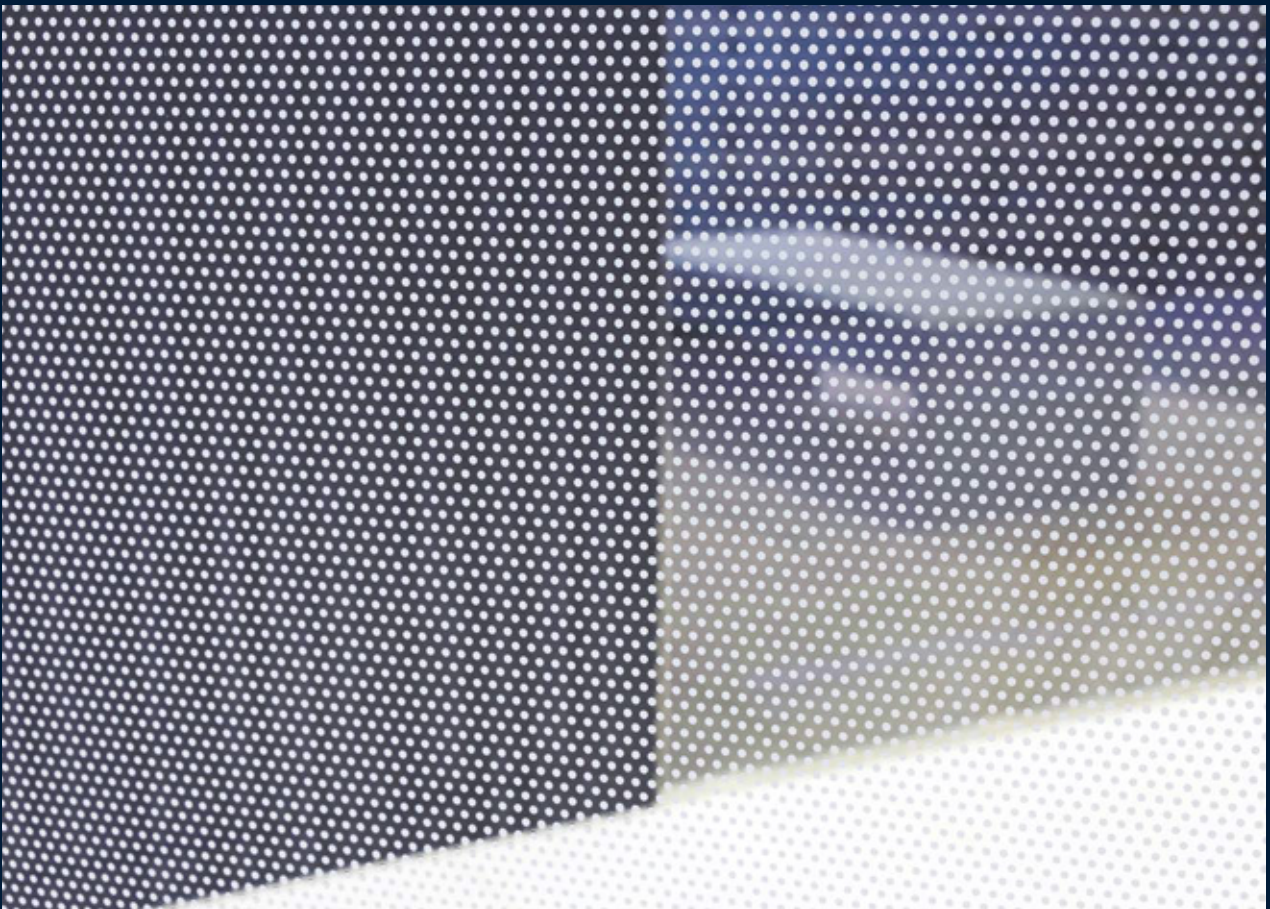

Vista SH2FGVI

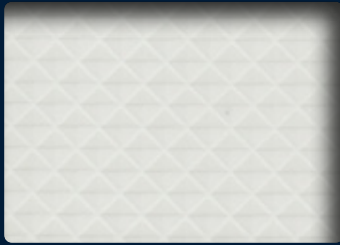

Cut Glass
SH2CSC

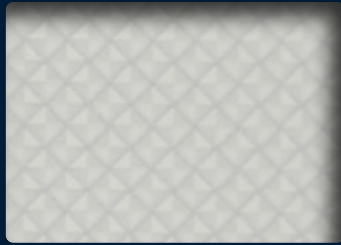

Cut Glass
SH2CSCP

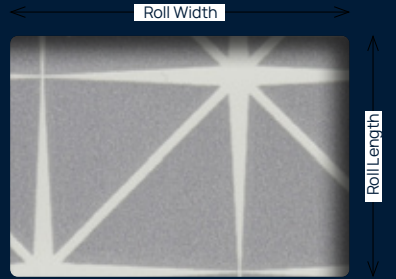

Astral silver
SH2CSAS



Vista
SH2FGVI



Shizuku
SH2FGSK



Kanon
SH2FGKN

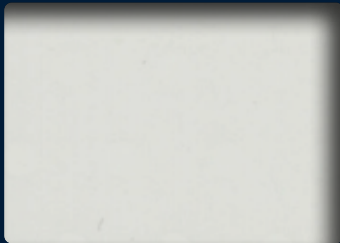

Aura 9
SH2PCA9



Luna 6
SH2PCL6



Luna 9
SH2PCL9

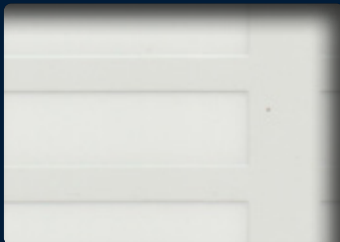

Lattice
SH2FGLT

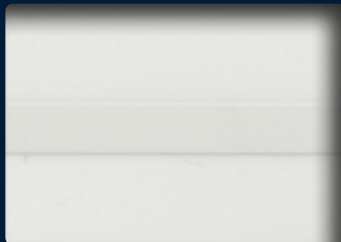

Slat
SH2FGSL

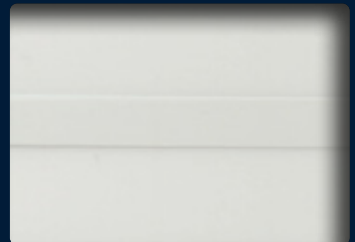

Slat-g
SH2FGSL-G

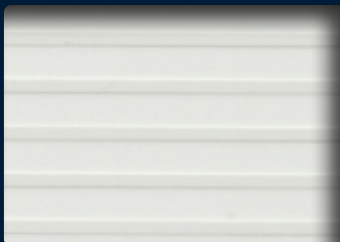

Paracell
SH2FGPR

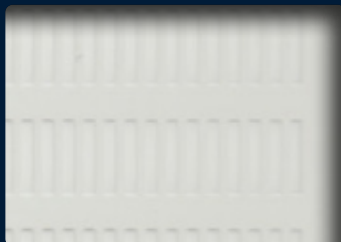

Pixela
SH2FGPX

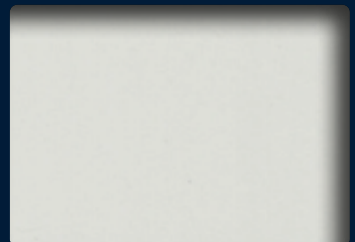

Leise
SH2FGLS

Stripe



String SH2PTST

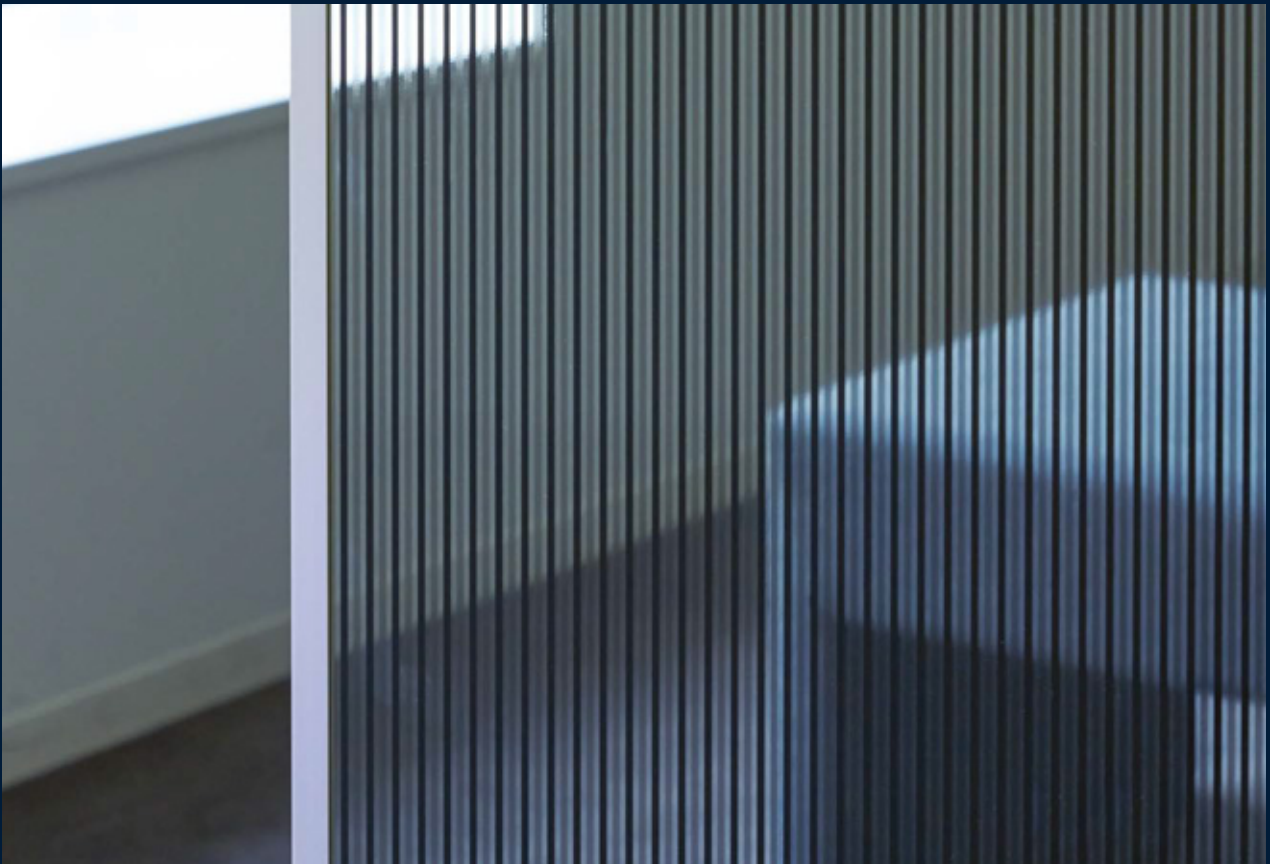

Shutie SH2BKST

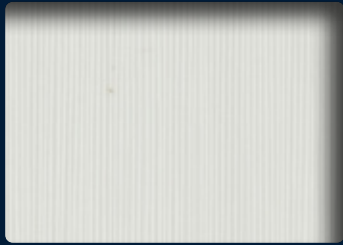

Fusion
SH2CSFP



Fine String
SH2PTFS

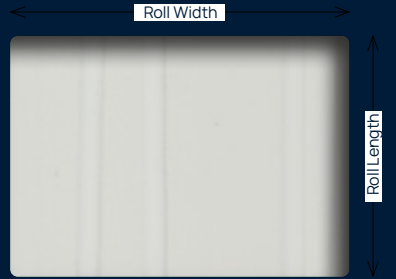

String
SH2PTST



Wind
SH2PTWD

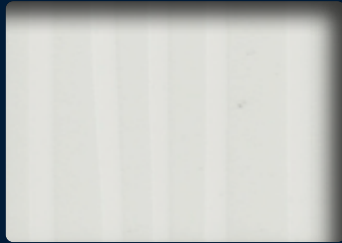

Safari
SH2PTSR

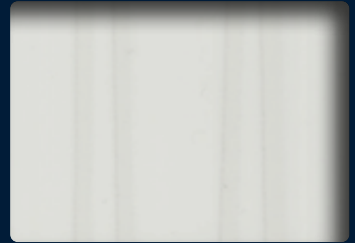

String Reverse
SH2PTSTR



Fine
SH2FGFN

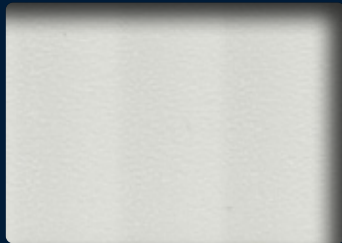

Seattle
SH2DGST

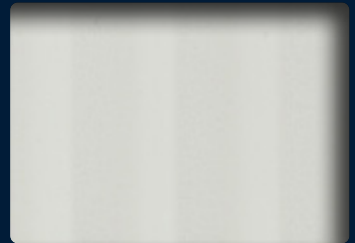

Seattle Fine
SH2DGST-F

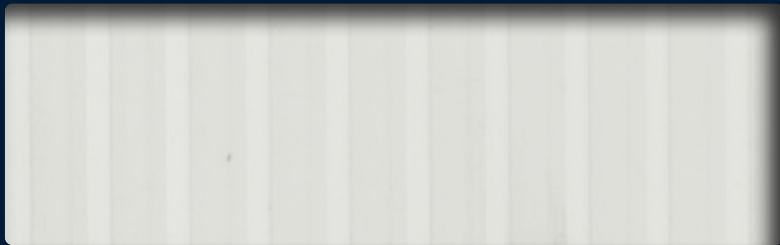

Shutie
SH2FGST

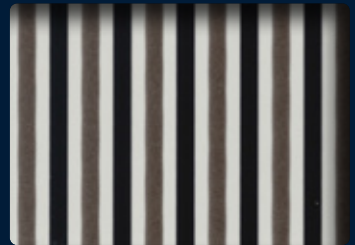

Shutie
SH2BKST



Arpa
SH2FGAP

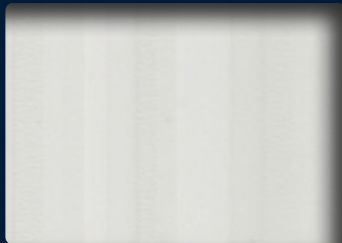

Arpa Crystal
SH2APCR

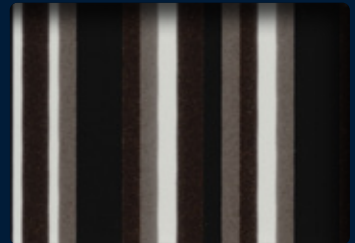

Arpa
SH2BKAP

3M™ DI-NOC™ Glass Finishes



FA-1161DG



FA-1678DG / FW-1022DG / FA-1528DG / ST-1587DG / FA-1161DG

Stripe



Wood

FW-1129DG DG-1129



Wood

FW-1022DG DG-1022



Wood

FW-1751DG DG-1751



Textile Silk

FA-1156DG DG-1156



Metallic Wood

MW-1419DG NEW



Abstract

FA-1161DG DG-1161



Textile Silk

SI-1689DG DG-1689



Textile

NU-1786DG DG-1786



Textile Silk

SI-1613DG DG-1613

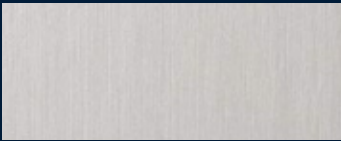

Metallic Hairline

ME-1716DG DG-1716



Metallic Hairline

ME-1434DG NEW



Metallic Hairline

ME-379DG DG-379

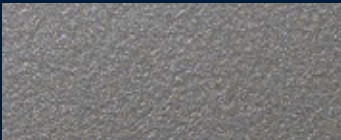

Metallic

ME-432DG DG-432



Metallic

PA-180DG NEW



Metallic Rust

RT-1827DG NEW

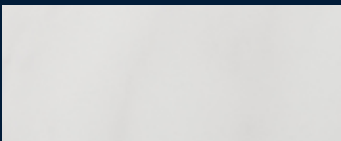

Stone

ST-1831DG DG-1831



Stone

ST-1587DG DG-1587



Mortar

AE-1719DG DG-1719

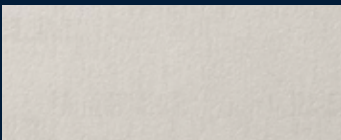

Abstract

FA-1678DG DG-1678



Abstract

FA-1528DG DG-1528



Solid Color

PS-503DG DG-503



Solid Color

PS-504DG DG-504

Dichroic

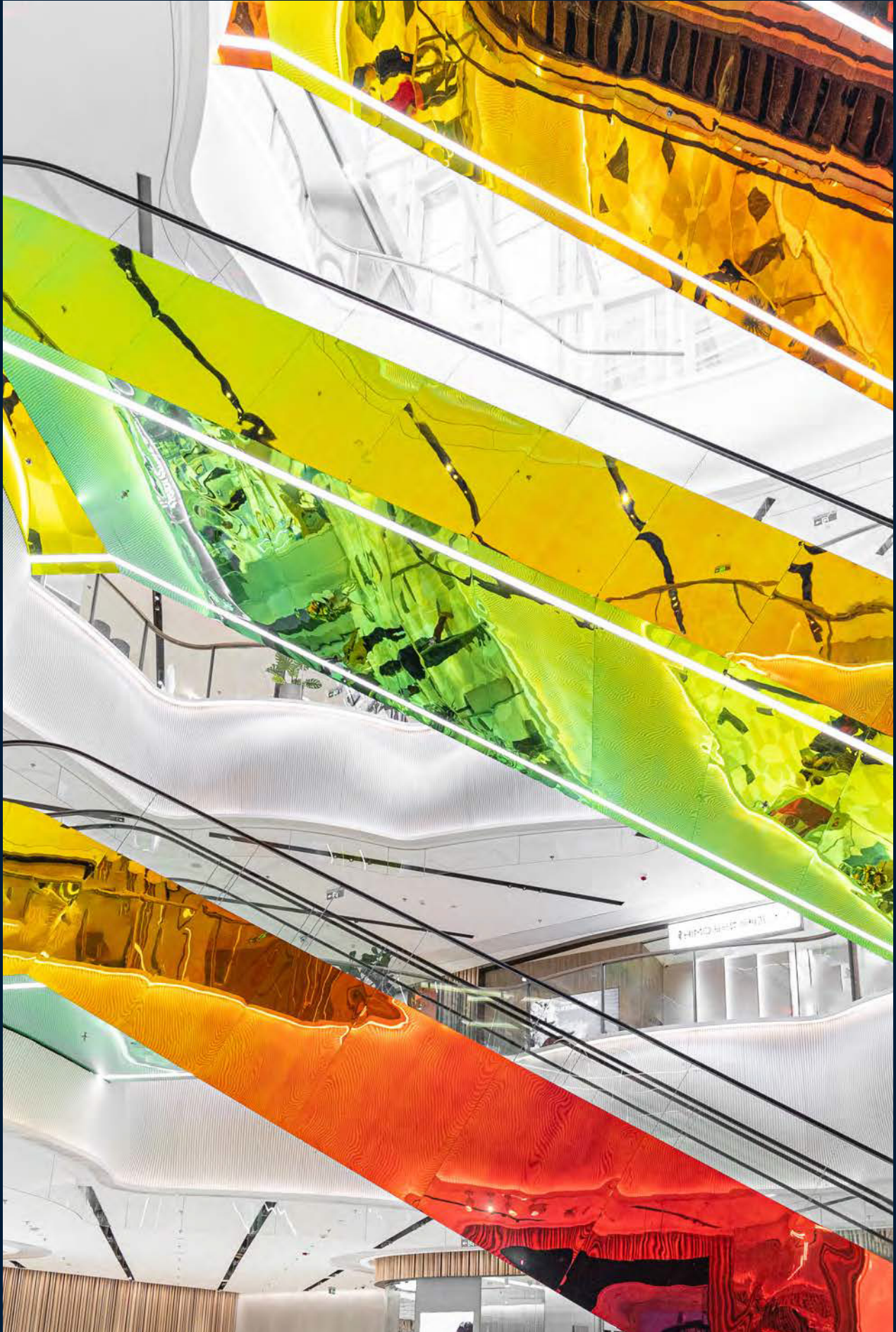

Dichroic Chill DF-PA

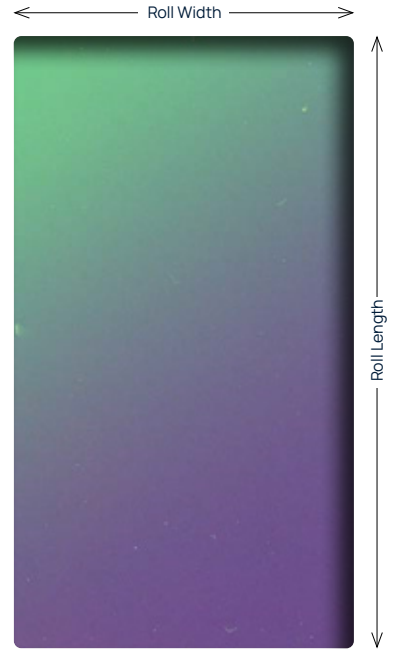

DF-PA Chill  Exterior



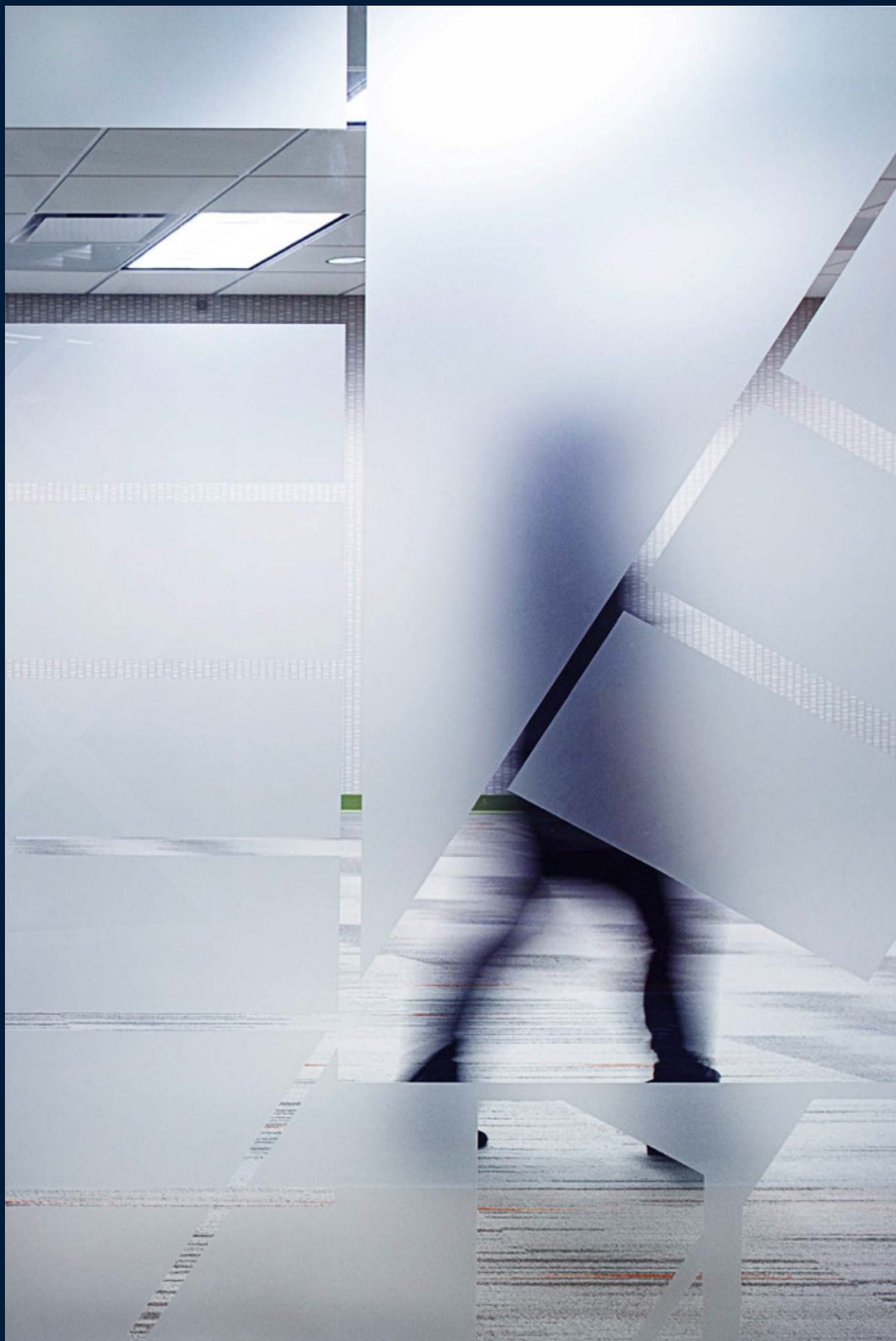

DF-PA Blaze  Exterior

Crystal Dusted and Frosted

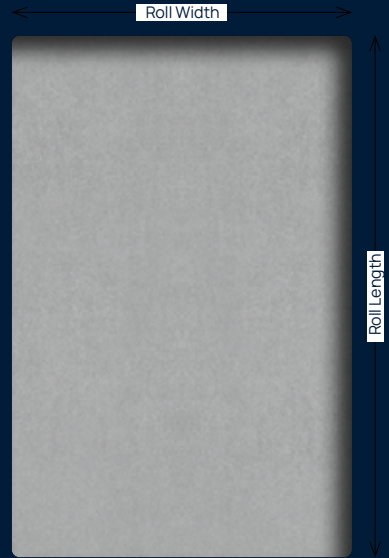

Dichroic



Dusted
7725SE-314 



Frosted
7725SE-324 



Frosted
7725SE-331 

Explore the possibilities with 3M™ Glass Finishes.

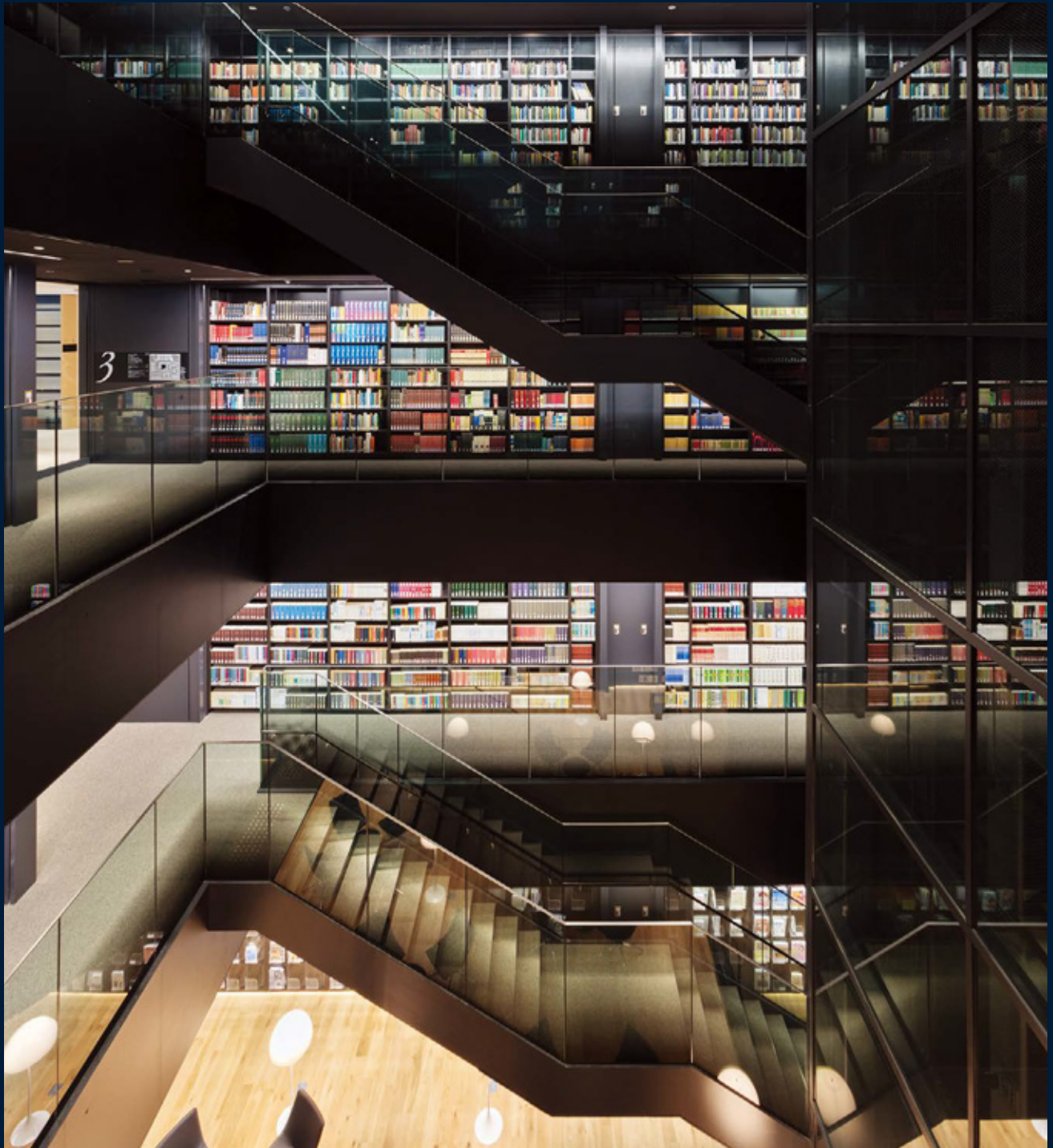

Illumina Reflect SH2SIIM